

4 3 2 1

D
C
B
A

D
C
B
A

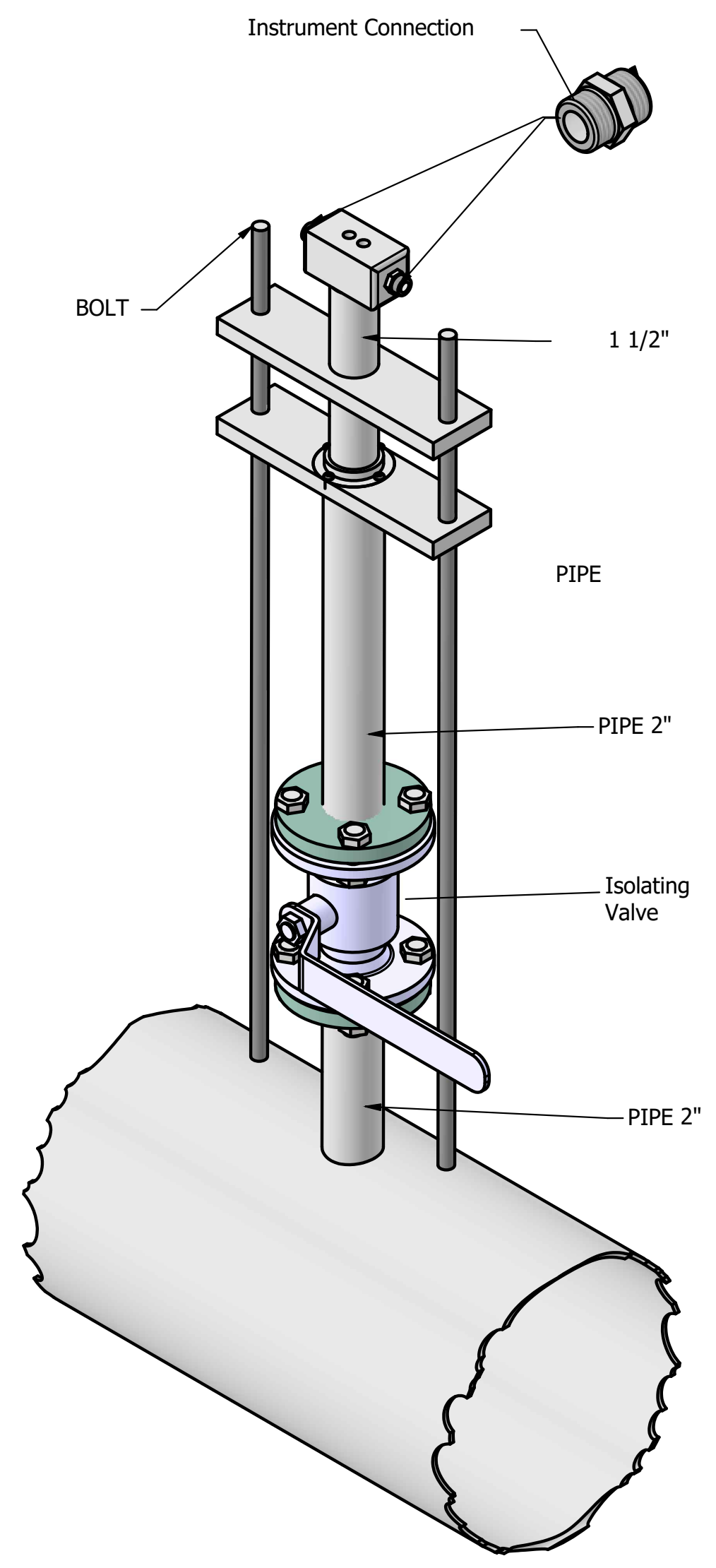
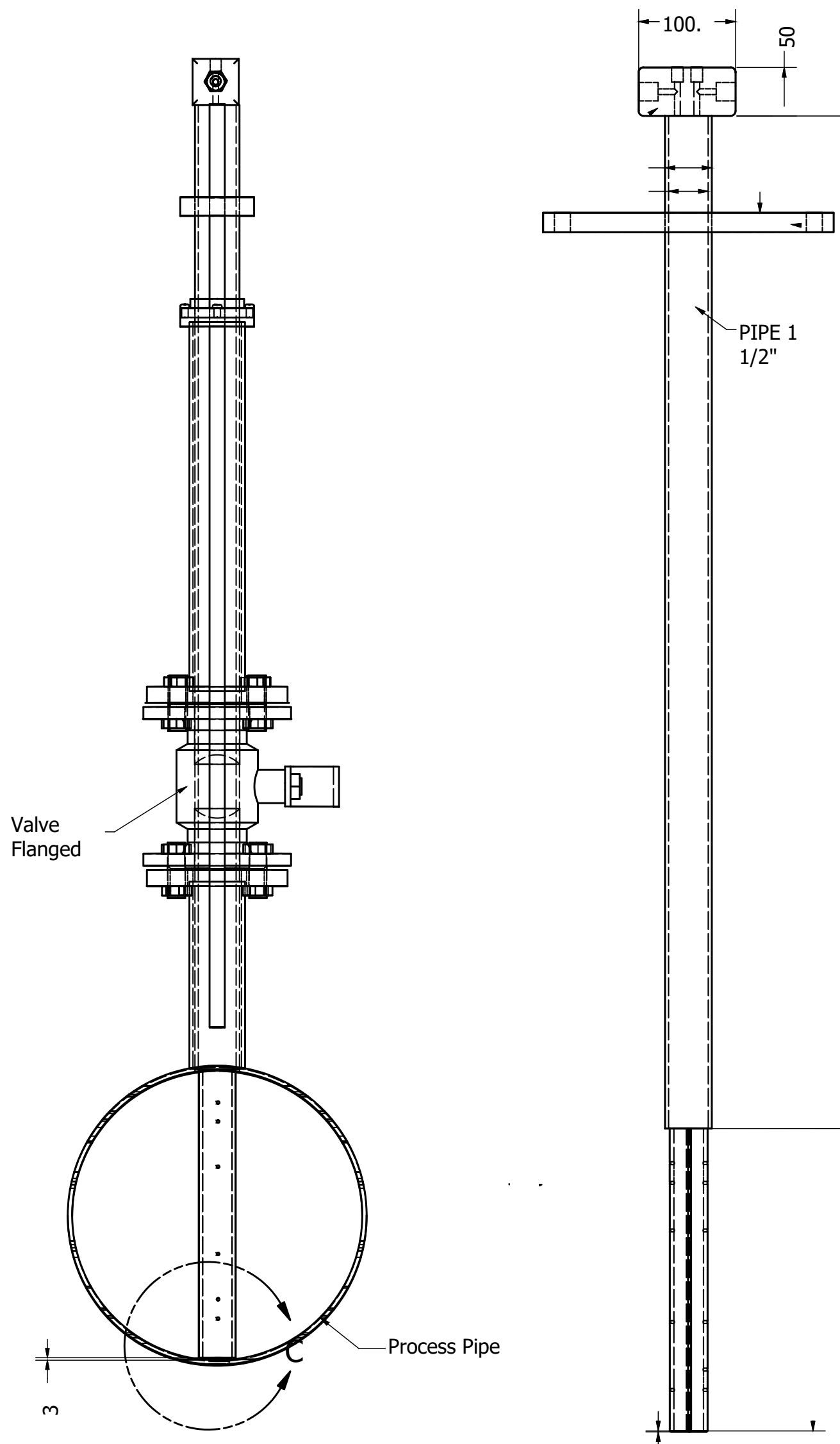
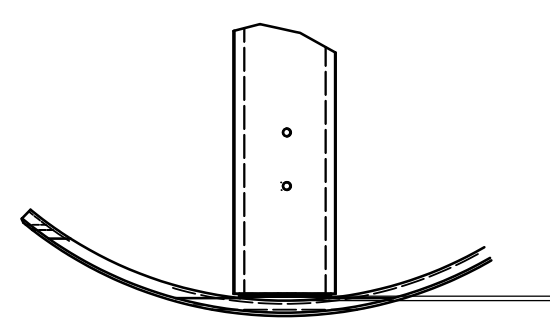

PART LIST			
ITEM	DESCRIPTION	MATERIAL	QTY.
1	Flange Rating		2
2	Pipe ID (mm)		1
3	Pitot Material		2
4	Pipe Material		
5	BOLT	S.S.	2
6	TAP		2

DESCRIPTION: **Pitot Tube**

DRAWN BY: **MR.Yadegary**
 CHEKED BY: **MR.Zarrineh**
 DESIGNED BY: **MR.zalpour**

2024/11/03
 2024/11/03
 2024/11/03

PURCHASE:
 NOTE:
 Drawing no t to scale
 Unit:mm



ARAMAK SANAT HOOSHMAND
 WWW.ARAMAKCO.COM
 EMAIL: SALES@ARAMAKCO.COM

4 3 2 1

Rev:00