

NO.	QTY.	TAG	DESCRIPTION	BODY MATERIAL	PROCESS CONNECTION	TOTAL LENGHT (L)	D	dD
1		Flow Indicator 360 View	S.S 316L	FLANGEmm	Ø....mm	Ø.... mm

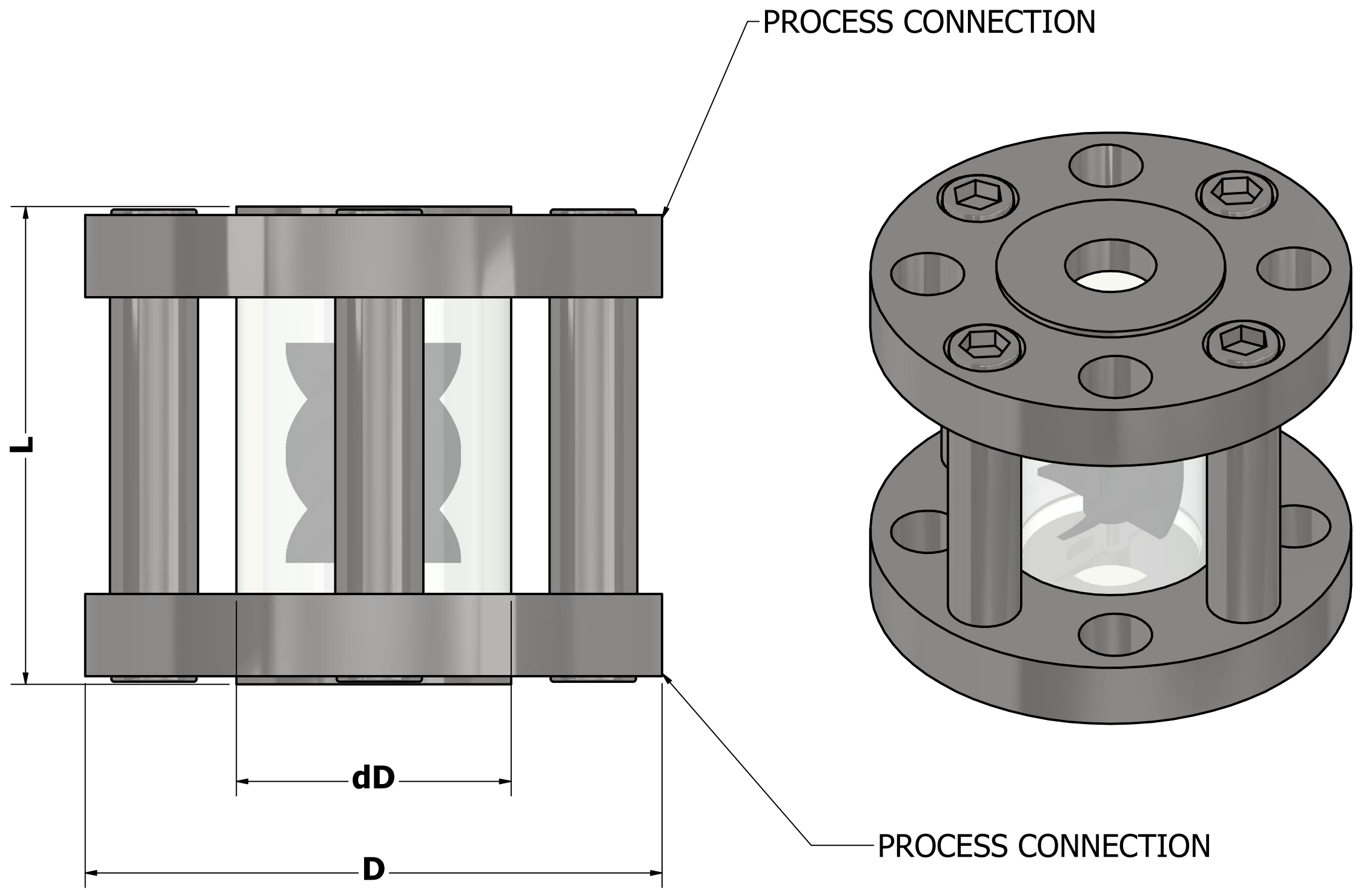
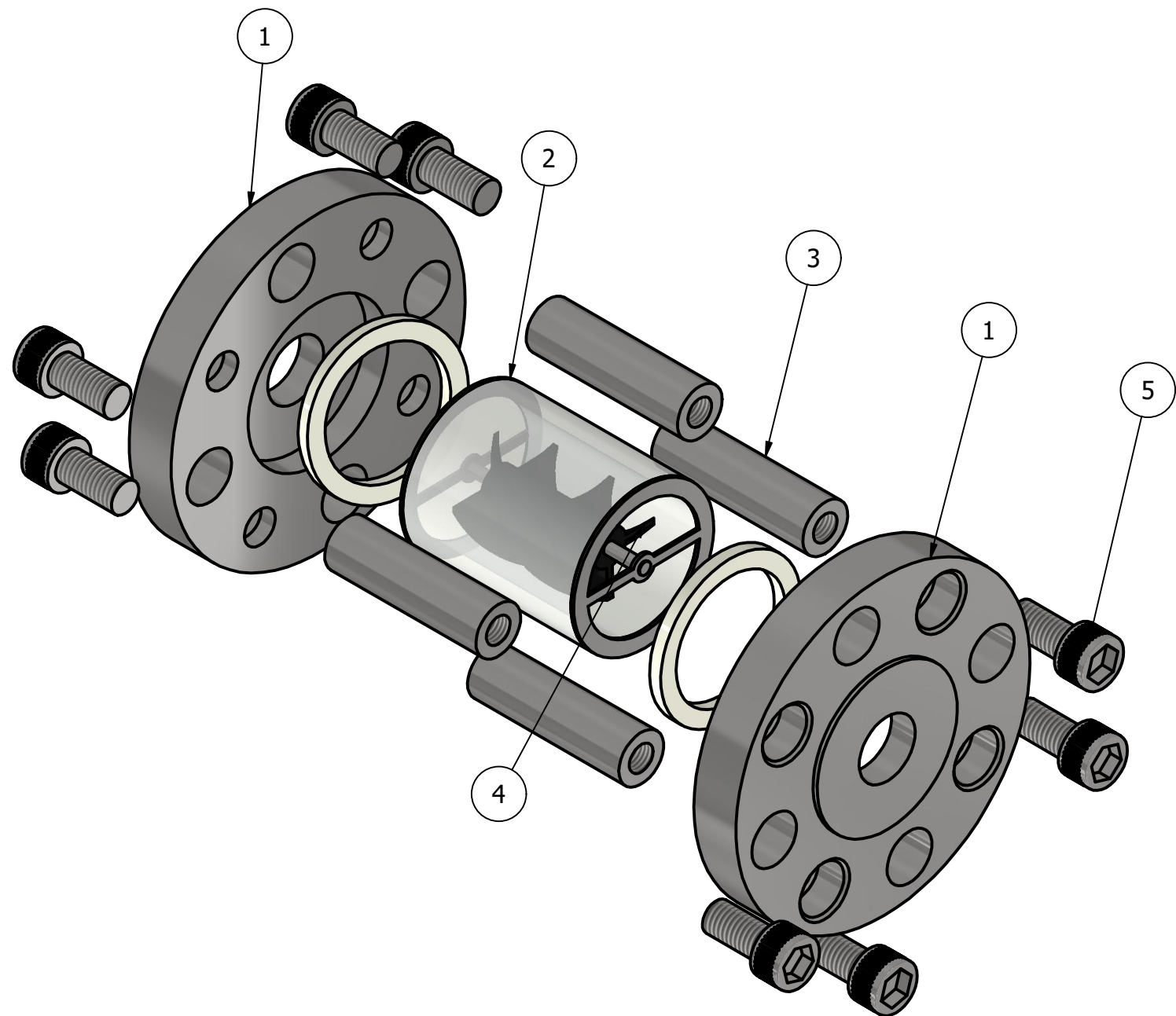

PART LIST			
ITEM	DESCRIPTION	MATERIAL	QTY.
1	FLANGE RF#.....	S.S 316L	2
2	GLASS	Borosilicate	1
3	STAND	S.S 316L	4
4	Propeller	PLA	1
5	ALLEN BOLT M10	S.S	8

TOLERANCE TABLE	
D DIM.	±1 mm
L DIM.	±2 mm
dD DIM	±0.5 mm

DESCRIPTION:
Flow Indicator 360 View

DRAWN BY: **MR.Yadegary**
 CHEKED BY: **MR.Zarrineh**
 DESIGNED BY: **MR.zalpour**

2026/06/10
 2026/06/10
 2026/06/10

PURCHASE:

NOTE:
 Drawing is not to scale
 Unit:mm

ARAMAK SANAT HOOSHMAND

Rev:00 WWW.ARAMAKCO.COM

EMAIL: SALES@ARAMAKCO.COM