

| NO. | QTY. | TAG | DESCRIPTION | MATERIAL | SIZE | Capacity | SCH | D | L | CONNECTION | N1 | N2 | N3 | N4 | N5 | N6 |
|-----|------|-----|-------------|----------|------|------------|--------|--------|--------|------------|----|----|----|----|----|----|
| 1 | XX | XXX | SEAL POT | S.S 316L | 3" | XXX LITERS | SCH 40 | Ø 88.9 | XXX mm | 1/2" NPTF | XX | XX | XX | XX | XX | XX |

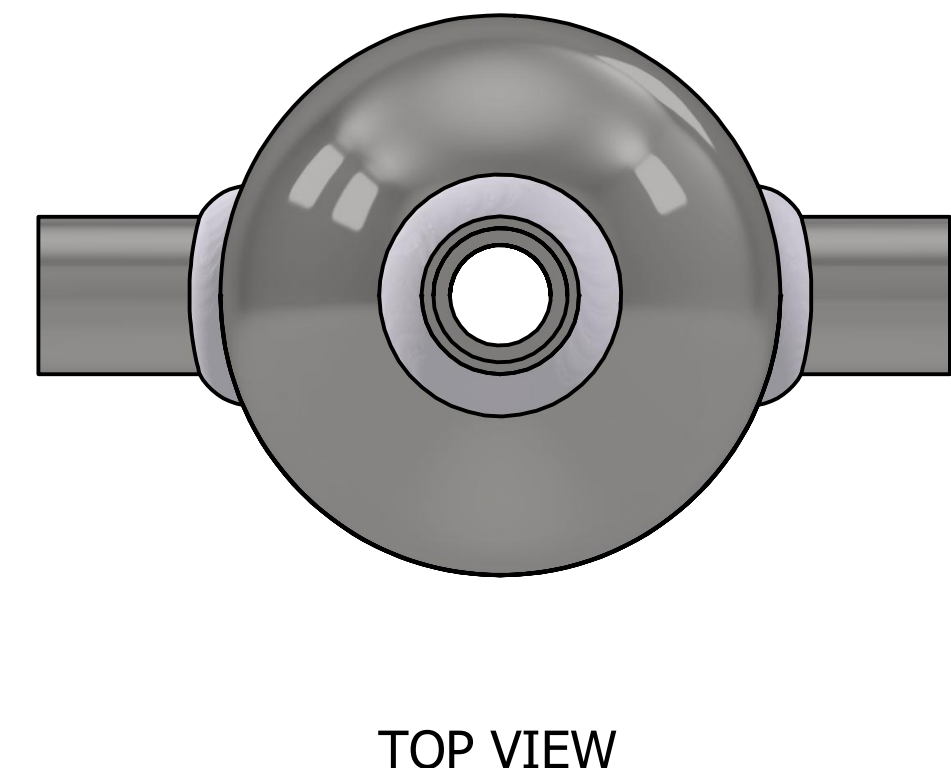
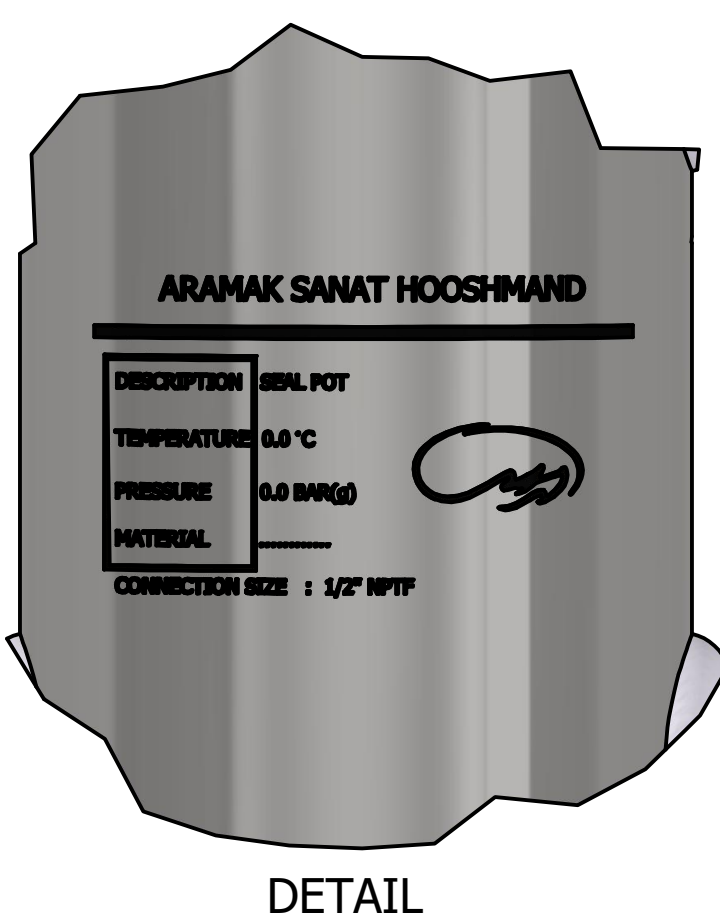
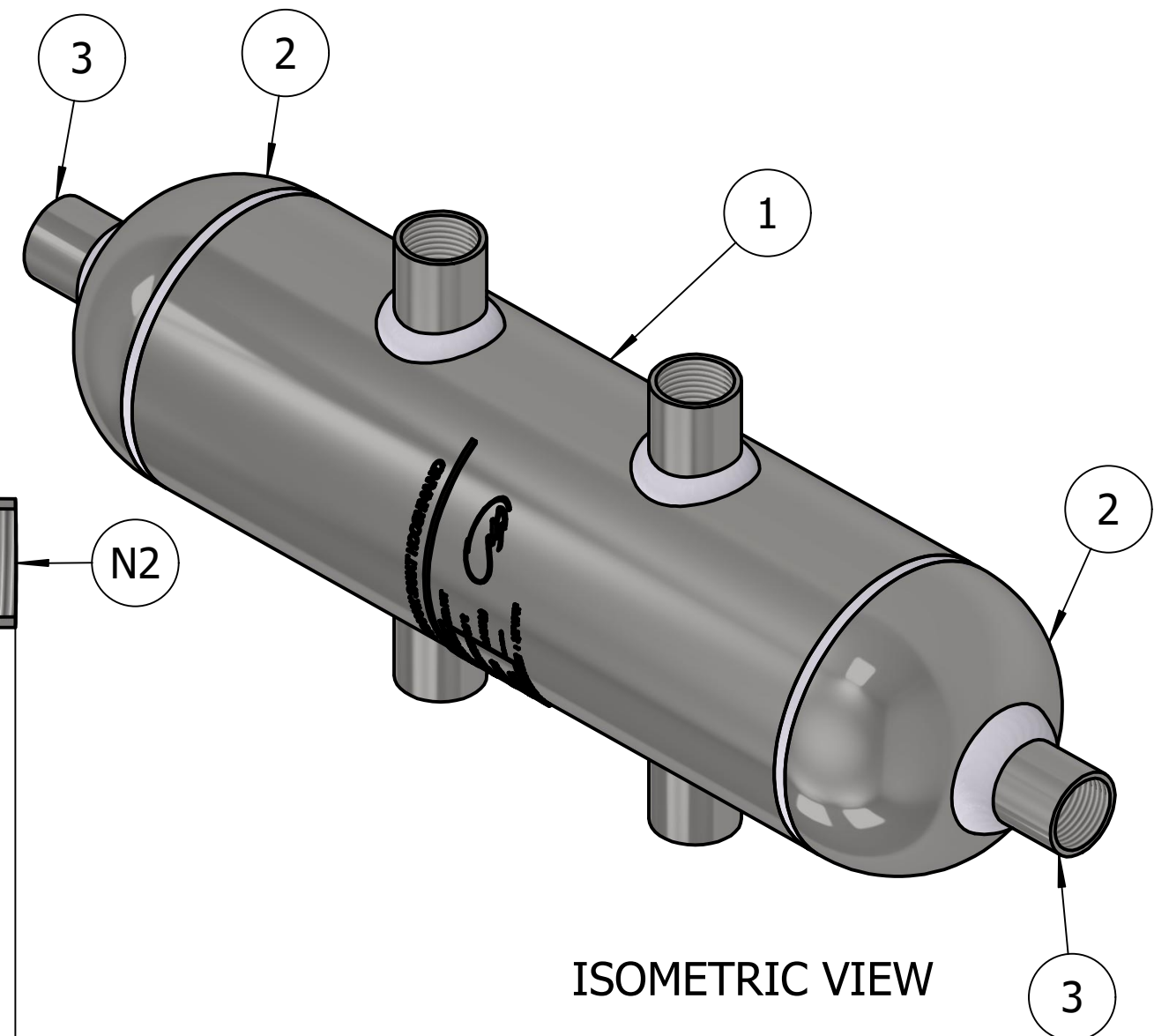
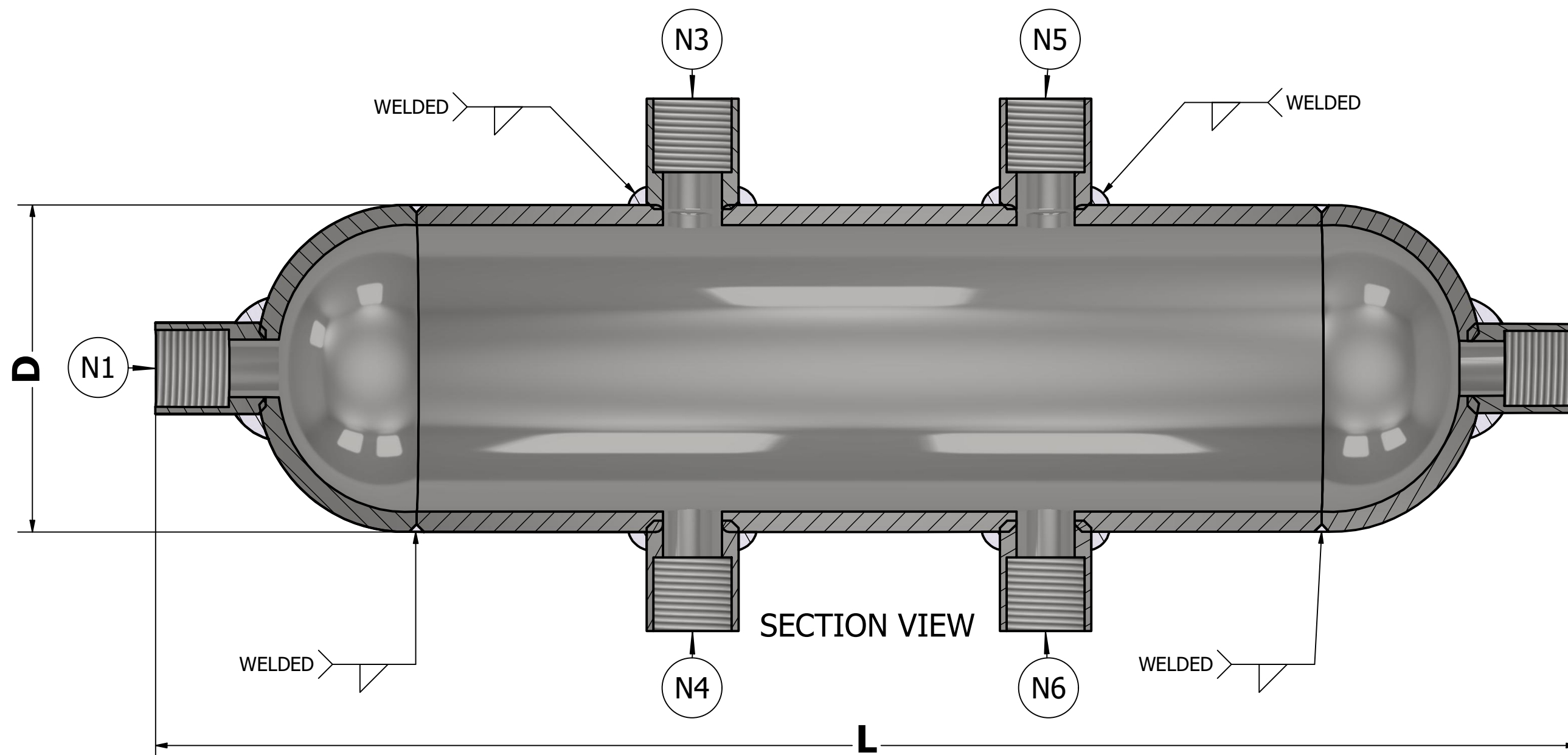

| TOLERANCE TABLE | |
|-----------------|--------|
| L DIM. | ± 3 mm |

| PART LIST | | | |
|-----------|--------------------------------|----------|------|
| ITEM | DESCRIPTION | MATERIAL | QTY. |
| 1 | BODY | S.S 316L | 1 |
| 2 | CAP | S.S 316L | 2 |
| 3 | CONNECTION 1/2" NPTF (3000PSI) | S.S 316L | 4 |

DESCRIPTION: **SEAL POT**

DRAWN BY: **MR.Yadegary**
 CHEKED BY: **MR.Zarrineh**
 DESIGNED BY: **MR.zalpour**

2026/00/00
 2026/00/00
 2026/00/00

PURCHASE:

NOTE:
 Drawing is not to scale
 Unit:mm

ARAMAK SANAT HOOSHMAND